

Smartsan have recently completed an installation of over one hundred Smartsan 8000 plus safety light curtains and control systems in one of the most advanced production plants in Europe.

The new Quinn Glass plant at Elton near Liverpool has a glass bottle production capacity of four million units a day. It operates 365 days a year and during peak periods handles 340 pallets per hour.



The infeed and outfeed conveyors to each of the twenty-four cranes inside the high-bay warehouse are safeguarded with Smartsan 8000 plus light curtains. Each crane aisle incorporates 8 light curtains and a control system to provide a simple but highly effective control of the safety

-1.145 TD0.0008 Tc□1.3de rem aTwēm 1(.fe)5(ty 1 Tf0 10.02 -1342.8 0 10.42 2

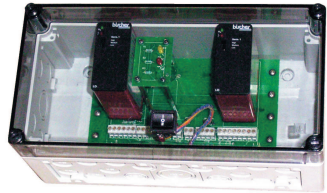
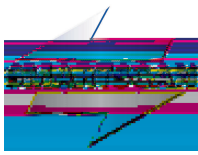

Smartscan dual loop controllers are used in a number of machine safety applications wherever the presence of fork lift trucks or other industrial vehicles needs to be detected, for example, when entering safeguarded access-ways or, at pallet conveyors for loading and unloading.

Two different loop controllers are available - model SLC2, suitable for Category 2 application and SLC4 for Category 4 control integrity as defined in European Standard EN954-1.

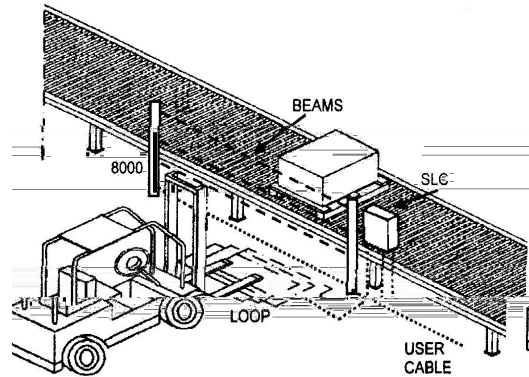

- Ease of use - automatic calibration of the system when the operating voltage is applied.
- Reliability - compensation for temperature fluctuation.
- Sensitivity setting - 3-position switch (high, medium, low).
- Simple fault detection with light-emitting diode to display possible malfunctions.
- Simple reset function - forces a re-calibration by changing the sensitivity. There is no need to shut off the voltage.
- Waterproof Enclosure – Smartscan loop controllers are mounted in an enclosure providing a protection rating of IP65
- Status Diagnostics – LED indicators for power, system reset (controller outputs 'on'), calibration complete, mute and inductive loop(s) outputs active.
- Smartscan loop controllers directly interface with all Series 8000 and 8000+ safety light-curtains.

The 8000 PLUS is Smartscan's new range of entry/exit self-muting safety light curtains for automated packaging lines and high-bay warehouses. Introduced specifically to address the special safeguarding requirements of those companies using fully automatic packaging machines where there are conveyor space constraints in relation to the mounting position of the lightcurtain.

The 8000 PLUS provides a multi-beam lightcurtain enabling the intangible barrier to be mounted as much as 60% closer to the dangerous parts of a machine than would normally be allowed with standard entry/exit systems.

The light curtains have a scanning range of up to 10m, mounted in robust IP65 rated enclosures, and are therefore suitable for harsh environments.



With safety integrity to Category 4 EN954-1 and the functionality and reliability of Smartscan's standard 8000 Series safety systems for packaging lines the 8000 PLUS is the ideal solution for machines where conveyor space is at a premium.

For technical information and documentation refer to the website www.smartscan.com or for a quote call the Sales Department on 01536 401313

